



AVIATION TECHNICAL BULLETIN

Champion Spark Plug Company

P. O. BOX 910, TOLEDO, OHIO 43601

ROUTE TO	
SERVICE MANAGER	
SALES MANAGER	
BULLETIN BOARD	

October 20, 1976

NO.

76-9
**CONTROLLED
COPY**

CHAMPION FHE 267-2 IGNITER

The FHE267-2 igniter is a low voltage series igniter. A semi-conductor material bridges the electrodes and is required for proper function of ignition.

CLEANING

1. Wipe combustion deposits from exterior with a lint-free cloth.
2. Normally, the firing-end does not require cleaning, however, if carbon deposits are present they may be removed with a stiff bristle brush (not metal) for inspection. The semi-conductor may show signs of uneven erosion. This is normal and is not a cause for rejection.
3. Terminal well may be cleaned with a felt swab saturated in mineral spirits, methyl, wood or methanol alcohol.

INSPECTION

1. Visually check for mechanical damage. Reject if it shows impact damage or if the connector well or firing end insulator is cracked or loose.
2. Check firing end shell for chafing or fretting wear. This wear is not to exceed .015. If this wear is more than one-half the circumference of the shell, reject.
3. Reject if shell body is swollen or distorted.
4. Check igniter plug for electrical erosion. If erosion equals or exceeds this measurement, reject. SEE ILLUSTRATION:

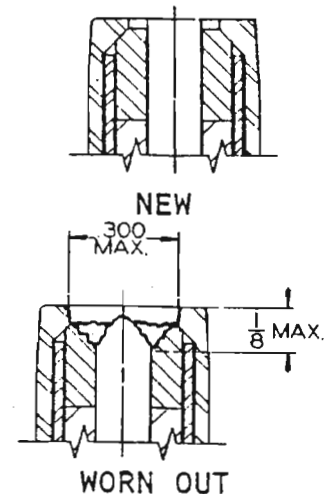

TESTING

1. Spark test. Test at normal open air pressure using the standard Viper engine ignition unit, including the shielded lead and terminal fittings.
2. Put three drops of turbine fuel on the firing end tip. Shake plug to remove excess fuel.
3. Connect the ignition unit to the igniter.
4. Clamp the igniter with the firing end up.
5. Switch on the ignition unit. Wait 30 seconds, then test fire. Allow the igniter to fire consistently for 15 seconds. (If misfiring or irregularity in sparking occurs, reject).
6. Turn off the ignition unit.

WARNING: THE OUTPUT OF THIS IGNITION SYSTEM IS SUFFICIENT TO CAUSE A LETHAL ELECTRICAL SHOCK. DO NOT TOUCH ANY EXPOSED OR LIVE PORTION. ALWAYS DISCONNECT LEADS FROM INPUT POWER SOURCE AND WAIT AT LEAST ONE MINUTE TO PERMIT STORED ENERGY TO DISSIPATE BEFORE WORKING WITH IGNITION UNIT.

7. Wait for at least one minute to elapse; disconnect the igniter from the ignition unit, then unclamp the igniter.

Before installing igniter, replace installation gasket with new Champion gasket, part number CH63008.
